

www.wackergroup.com

0154566en	007
0707	

Vibroplate

VP 1135A

VP 1135AW

OPERATOR'S MANUAL

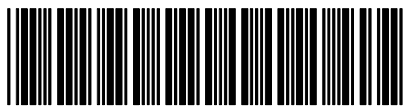

0 1 5 4 5 6 6 E N

1. Foreword	3
2. Safety Information	4
2.1 Laws Pertaining to Spark Arresters	5
2.2 Operating Safety	5
2.3 Operator Safety while using Internal Combustion Engines	6
2.4 Service Safety	7
2.5 Label Locations	8
2.6 Warning and Informational Labels	9
3. Technical Data	11
3.1 Engine Data	11
3.2 Machine Data	11
3.3 Sound and Vibration Measurements	12
3.4 Dimensions	12
4. Operation	13
4.1 Recommended Fuel	13
4.2 Application	13
4.3 Before Starting	13
4.4 To Start	14
4.5 To Stop	14
4.6 Operation	15

5. Maintenance	16
5.1 Periodic Maintenance Schedule	16
5.2 Spark Plug	17
5.3 Air Cleaner	18
5.4 Engine Oil	19
5.5 Adjusting Engine Speed	19
5.6 Carburetor Adjustment	20
5.7 Cleaning Sediment Cup	20
5.8 Drive Belt	21
5.9 Exciter Lubrication	22
5.10 Cleaning the Plate	22
5.11 Lifting Machine	23
5.12 Transporting Machine	24
5.13 Storage	24
5.14 Troubleshooting	25

CALIFORNIA

Proposition 65 Warning:



Engine exhaust, some of its constituents, and certain vehicle components, contain or emit chemicals known to the State of California to cause cancer and birth defects or other reproductive harm.

1. Foreword

This manual provides information and procedures to safely operate and maintain this Wacker model. For your own safety and protection from injury, carefully read, understand and observe the safety instructions described in this manual.

Keep this manual or a copy of it with the machine. If you lose this manual or need an additional copy, please contact Wacker Corporation. This machine is built with user safety in mind; however, it can present hazards if improperly operated and serviced. Follow operating instructions carefully! If you have questions about operating or servicing this equipment, please contact Wacker Corporation.

The information contained in this manual was based on machines in production at the time of publication. Wacker Corporation reserves the right to change any portion of this information without notice.

All rights, especially copying and distribution rights, are reserved.

Copyright 2007 by Wacker Corporation.

No part of this publication may be reproduced in any form or by any means, electronic or mechanical, including photocopying, without express written permission from Wacker Corporation.

Any type of reproduction or distribution not authorized by Wacker Corporation represents an infringement of valid copyrights and will be prosecuted. We expressly reserve the right to make technical modifications, even without due notice, which aim at improving our machines or their safety standards.

2. Safety Information

This manual contains DANGER, WARNING, CAUTION, *NOTICE* and NOTE callouts which must be followed to reduce the possibility of personal injury, damage to the equipment, or improper service.



This is the safety alert symbol. It is used to alert you to potential personal injury hazards. Obey all safety messages that follow this symbol to avoid possible injury or death.



DANGER

DANGER indicates a hazardous situation which, if not avoided, will result in death or serious injury.



WARNING

WARNING indicates a hazardous situation which, if not avoided, could result in death or serious injury.



CAUTION

CAUTION indicates a hazardous situation which, if not avoided, could result in minor or moderate injury.

NOTICE: Used without the safety alert symbol, **NOTICE** indicates a hazardous situation which, if not avoided, could result in property damage.

Note: *Contains additional information important to a procedure.*

2.1 Laws Pertaining to Spark Arresters

Notice: State Health Safety Codes and Public Resources Codes specify that in certain locations spark arresters be used on internal combustion engines that use hydrocarbon fuels. A spark arrester is a device designed to prevent accidental discharge of sparks or flames from the engine exhaust. Spark arresters are qualified and rated by the United States Forest Service for this purpose.

In order to comply with local laws regarding spark arresters, consult the engine distributor or the local Health and Safety Administrator.

2.2 Operating Safety



WARNING

Familiarity and proper training are required for the safe operation of the machine. Machines operated improperly or by untrained personnel can be dangerous. Read the operating instructions contained in both this manual and the Engine Manual and familiarize yourself with the location and proper use of all controls. Inexperienced operators should receive instruction from someone familiar with the machine before being allowed to operate it.

- 2.2.1 NEVER allow anyone to operate this equipment without proper training. People operating this equipment must be familiar with the risks and hazards associated with it.
- 2.2.2 NEVER touch the engine or muffler while the engine is on or immediately after it has been turned off. These areas get hot and may cause burns.
- 2.2.3 NEVER use accessories or attachments that are not recommended by Wacker. Damage to equipment and injury to the user may result.
- 2.2.4 NEVER operate the machine with the beltguard missing. Exposed drive belt and pulleys create potentially dangerous hazards that can cause serious injuries.
- 2.2.5 NEVER leave the machine running unattended.
- 2.2.6 ALWAYS be sure operator is familiar with proper safety precautions and operation techniques before using machine.
- 2.2.7 ALWAYS wear protective clothing appropriate to the job site when operating the machine.
- 2.2.8 ALWAYS wear hearing protection when operating equipment.
- 2.2.9 ALWAYS close fuel valve on engines equipped with one when machine is not being operated.
- 2.2.10 ALWAYS store the machine properly when it is not being used. The machine should be stored in a clean, dry location out of the reach of children.
- 2.2.11 ALWAYS operate machine with all safety devices and guards in place and in working order. DO NOT modify or defeat safety devices. DO NOT operate machine if any safety devices or guards are missing or inoperative.
- 2.2.12 ALWAYS read, understand, and follow procedures in the Operator's Manual before attempting to operate the machine.

2.3 Operator Safety while using Internal Combustion Engines



DANGER

Internal combustion engines present special hazards during operation and fueling. Read and follow the warning instructions in the engine Owner's Manual and the safety guidelines below. Failure to follow the warnings and safety standards could result in severe injury or death.

- 2.3.1 DO NOT run the machine indoors or in an enclosed area such as a deep trench unless adequate ventilation, through such items as exhaust fans or hoses, is provided. Exhaust gas from the engine contains poisonous carbon monoxide gas; exposure to carbon monoxide can cause loss of consciousness and may lead to death.
- 2.3.2 DO NOT smoke while operating the machine.
- 2.3.3 DO NOT smoke when refueling the engine.
- 2.3.4 DO NOT refuel a hot or running engine.
- 2.3.5 DO NOT refuel the engine near an open flame.
- 2.3.6 DO NOT spill fuel when refueling the engine.
- 2.3.7 DO NOT run the engine near open flames.
- 2.3.8 ALWAYS refill the fuel tank in a well-ventilated area.
- 2.3.9 ALWAYS replace the fuel tank cap after refueling.
- 2.3.10 ALWAYS check the fuel lines and the fuel tank for leaks and cracks before starting the engine. Do not run the machine if fuel leaks are present or the fuel lines are loose.

2.4 Service Safety

**WARNING**

A poorly maintained machine can become a safety hazard! In order for the machine to operate safely and properly over a long period of time, periodic maintenance and occasional repairs are necessary.

- 2.4.1 DO NOT attempt to clean or service the machine while it is running. Rotating parts can cause severe injury.
- 2.4.2 DO NOT crank a flooded engine with the spark plug removed on gasoline-powered engines. Fuel trapped in the cylinder will squirt out the spark plug opening.
- 2.4.3 DO NOT test for spark on gasoline-powered engines if the engine is flooded or the smell of gasoline is present. A stray spark could ignite the fumes.
- 2.4.4 DO NOT use gasoline or other types of fuels or flammable solvents to clean parts, especially in enclosed areas. Fumes from fuels and solvents can become explosive.
- 2.4.5 ALWAYS keep the area around the muffler free of debris such as leaves, paper, cartons, etc. A hot muffler could ignite the debris and start a fire.
- 2.4.6 ALWAYS replace worn or damaged components with spare parts designed and recommended by Wacker Corporation.
- 2.4.7 ALWAYS disconnect the spark plug on machines equipped with gasoline engines, before servicing, to avoid accidental start-up.
- 2.4.8 ALWAYS keep the machine clean and labels legible. Replace all missing and hard-to-read labels. Labels provide important operating instructions and warn of dangers and hazards.



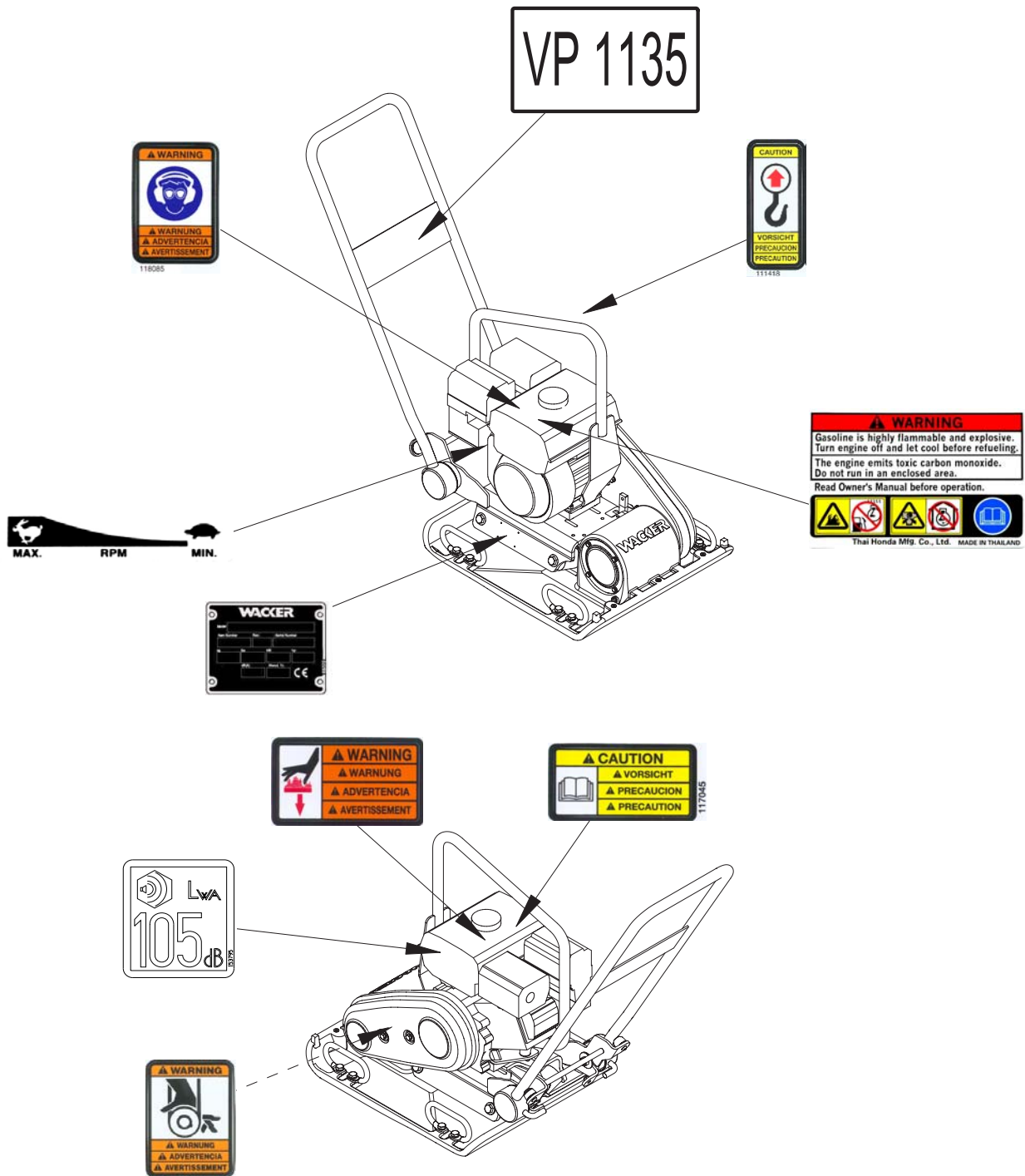



2.5 Label Locations







wpm_gr002147

2.6 Warning and Informational Labels

Wacker machines use international pictorial labels where needed. These labels are described below:

Label	Meaning
	<p>WARNING! Hot surface!</p>
	<p>Guaranteed sound power level in dB(A).</p>
	<p>WARNING! Hand injury if caught in moving belt. Always replace beltguard.</p>
	<p>CAUTION! Read and understand the supplied Operator's Manuals before operating this machine. Failure to do so increases the risk of injury to yourself or others.</p>
	<p>CAUTION! Lifting point.</p>
	<p>WARNING! Always wear hearing and eye protection when operating this machine.</p>

Label	Meaning
	<p>Throttle control lever: Turtle = Idle or Slow Rabbit = Full or Fast</p>
	<p>DANGER! Engines emit carbon monoxide; operate only in well-ventilated area. Read the Operator's Manual. No sparks, flames, or burning objects near the machine. Shut off the engine before refueling.</p>
	<p>Label-machine model</p>
	<p>A nameplate listing the model number, item number, revision number, and serial number is attached to each unit. Please record the information found on this plate so it will be available should the nameplate become lost or damaged. When ordering parts or requesting service information, you will always be asked to specify the model number, item number, revision number, and serial number of the unit.</p>
	<p>This machine may be covered by one or more patents.</p>

3. Technical Data

3.1 Engine Data

		VP 1135A 0009057	VP 1135AW 0009058
Engine			
Engine Make		Honda	
Engine Model		GX 120 UT1 SWX2	
Rated Power	kW (Hp)	2.6 (3.5)	
Spark Plug		BPR6ES (NGK) W20EPR-V (DENSO)	
Electrode Gap	mm (in.)	0.7-0.8 (0.028–0.031)	
Engine Speed	rpm	3900 ± 100	
Air Cleaner	type	Dual element	
Engine Lubrication	oil grade	SAE 10W30 SG or SF	
Engine Oil Capacity	ml (oz.)	560 (19)	
Fuel	type	Regular unleaded gasoline	
Fuel Tank Capacity	l (qts.)	2.5 (2.6)	

3.2 Machine Data

		VP 1135A 0009057	VP 1135AW 0009058
Plate			
Weight	kg (lbs.)	62 (137)	65 (143)
Water Tank Capacity	l (qts.)	7.6 (8)	
Exciter Speed	rpm	5800 ± 100	
Exciter Lubrication	ml (oz.)	207 (7) Automatic transmission fluid Dextron III/Mercon or equivalent	
Dimensions	mm (in.)	521 (21) x 350 (14) x 905 (35)	

3.3 Sound and Vibration Measurements

The required sound specification, Paragraph 1.7.4.f of 89/392/EEC Machinery Directive, is:

- the guaranteed sound power level (L_{WA}) = 105 dB(A).
- the sound pressure level at operator's location (L_{pA}) = 93 dB(A).

These sound values were determined according to ISO 3744 for the sound power level (L_{WA}) and ISO 6081 for the sound pressure level (L_{pA}) at the operator's location.

The weighted effective acceleration value, determined according to EN ISO 5349, is approximately 4.5 m/s^2 .

The sound and vibration measurements were obtained with the machine operating on crushed gravel at nominal engine speed.

3.4 Dimensions

mm (in.)

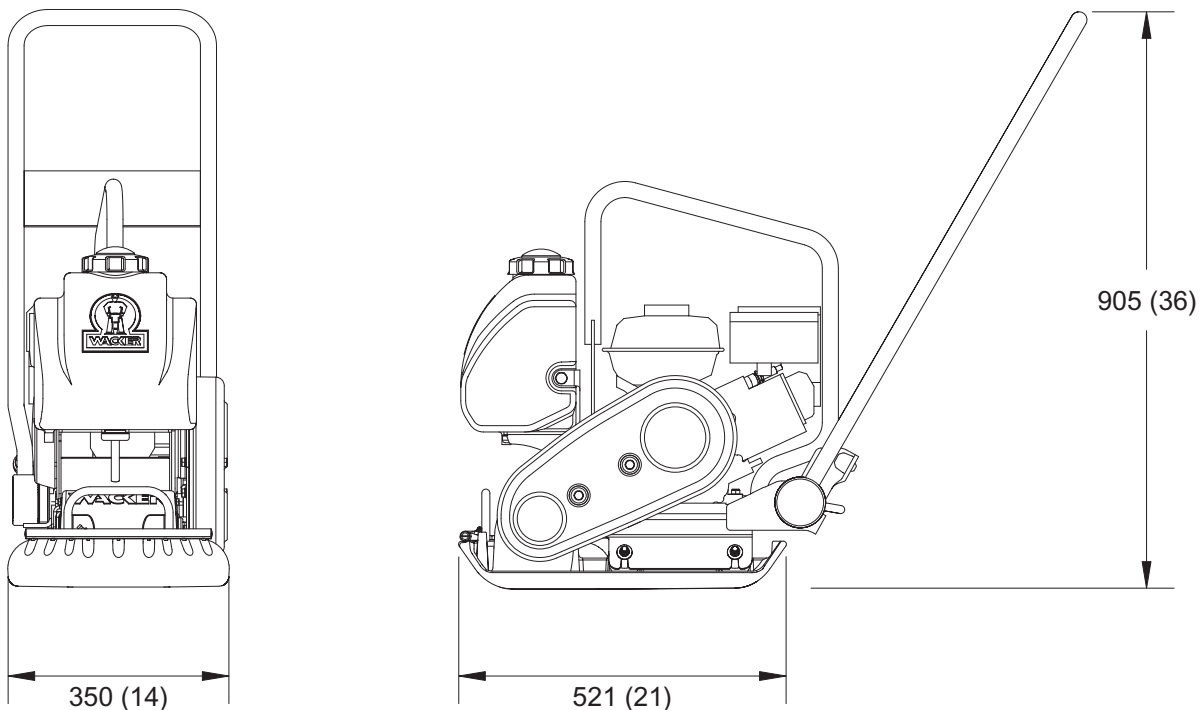

wpm_gr002146

4. Operation

4.1 Recommended Fuel

The engine requires regular grade unleaded gasoline. Use only fresh, clean gasoline. Gasoline containing water or dirt will damage fuel system. Consult engine Owner's Manual for complete fuel specifications.

4.2 Application

This plate is designed for compacting loose, granular soils, gravel, and paving stones. It is intended to be used in confined areas and areas next to structures such as walls, curbs, and foundations. Plates equipped with water tanks can be used for compacting asphalt.

This plate is not recommended for compacting cohesive soils with a heavy clay content. For cohesive soil, use a vibratory rammer or sheepfoot roller.

4.3 Before Starting

- 4.3.1 Read and understand the safety and operating instructions at the beginning of this manual.
- 4.3.2 Check:
 - Oil level in the engine
 - Fuel level
 - Condition of the air cleaner
 - Tightness of the external fasteners
 - Condition of the fuel lines

4.4 To Start

See Graphic: wc_gr000014

4.4.1 Open fuel valve by moving lever to the right (**a1**).

Note: If engine is cold, move choke lever to close position (**b1**). If engine is hot, set choke to open position (**b2**).

4.4.2 Turn engine switch to “ON” (**e1**).

4.4.3 Open throttle by moving it slightly to left (**d1**).

4.4.4 Pull starter rope (**c**).

Note: If the oil level in the engine is low, the engine will not start. If this happens, add oil to engine. Some engines are equipped with an oil alert light (**f**) that will come on while pulling the starter rope.

4.4.5 Open choke as engine warms (**b2**).

4.4.6 Open throttle fully to operate.

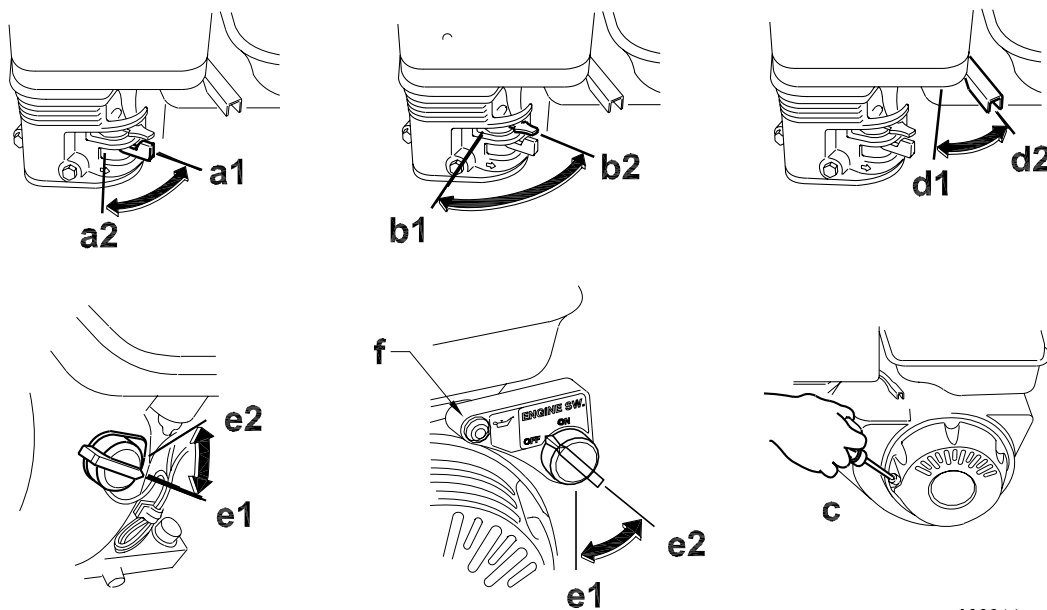

wc_gr000014

4.5 To Stop

See Graphic: wc_gr000014

4.5.1 Reduce engine RPM to idle by moving throttle completely to right (**d2**).

4.5.2 Turn engine switch to “OFF” (**e2**).

4.5.3 Close fuel valve by moving lever to the left (**a2**).

4.6 Operation

Run the engine at full throttle and allow the plate to pull itself along at its normal speed. When operating on an incline it may be necessary to assist the plate by pushing it forward slightly. When operating downhill hold the plate back slightly, if it begins to pick up speed. Depending on the material being compacted, three or four passes are recommended to achieve the best compaction.

While a certain amount of moisture in the soil is necessary, excessive moisture may cause soil particles to stick together and prevent good compaction. If soil is extremely wet, allow it to dry somewhat before compacting.

If soil is so dry as to create dust clouds while operating plate, some moisture should be added to the ground material to improve compaction. This will also reduce service to the air filter.

For compacting asphalt, use a water tank to wet the asphalt and the underside of plate. This will prevent asphalt material from sticking. Two passes are usually sufficient to ensure good compaction.

When using the plate on paving stones, attach a pad to the bottom of the plate to prevent chipping or grinding surface of stones. A special polyurethane pad designed for this purpose is available as an optional accessory.

NOTICE: DO NOT operate the plate on concrete or on extremely hard, dry, compacted surfaces. The plate will jump rather than vibrate and could damage both the plate and the engine.

5. Maintenance

5.1 Periodic Maintenance Schedule

The chart below lists basic machine and engine maintenance. Refer to your Wacker engine operator’s manual for additional information on engine maintenance.

	Daily before starting	After first 20 hours	Every two weeks or 50 hrs.	Every month or 100 hrs.	Every year or 300 hrs.
Check fuel level.	■				
Check engine oil level.	■				
Inspect fuel lines.	■				
Inspect air filter. Replace as needed.	■				
Check external hardware.	■				
Check and adjust drive belt.		■	■		
Clean air cleaner element.			■		
Inspect shockmounts for damage.			■		
Check exciter oil level.			■		
Change engine oil.		■		■	
Clean cooling system.				■	
Check and clean spark plug.				■	
Clean sediment cup.				■	
Check and adjust valve clearance.					■
Change exciter oil.					■

5.2 Spark Plug

See Graphic: *wc_gr000028*

Clean or replace the spark plug as needed to ensure proper operation. Refer to your engine operator's manual.



WARNING

The muffler becomes very hot during operation and remains hot for a while after stopping the engine. Do not touch the muffler while it is hot.

Note: Refer to the Technical Data for the recommended spark plug type and the electrode gap setting.

- 5.2.1 Remove the spark plug and inspect it.
- 5.2.2 Replace the spark plug if the insulator is cracked or chipped.
- 5.2.3 Clean the spark plug electrodes with a wire brush.
- 5.2.4 Set the electrode gap (**a**).
- 5.2.5 Tighten the spark plug securely.

NOTICE: A loose spark plug can become very hot and may cause engine damage.

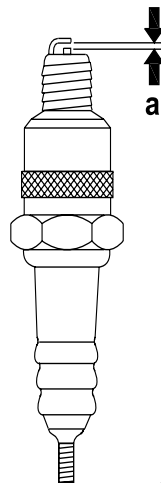

wc_gr000028

5.3 Air Cleaner

See Graphic: *wc_gr000025*

The engine is equipped with a dual element air cleaner. Service air cleaner frequently to prevent carburetor malfunction.

NOTICE: NEVER run engine without air cleaner. Severe engine damage will occur.



WARNING

NEVER use gasoline or other types of low flash point solvents for cleaning the air cleaner. A fire or explosion could result.

To service:

- 5.3.1 Remove air cleaner cover **(a)**. Remove both elements and inspect them for holes or tears. Replace damaged elements.
- 5.3.2 Wash foam element **(b)** in solution of mild detergent and warm water. Rinse thoroughly in clean water. Allow element to dry thoroughly. Soak element in clean engine oil and squeeze out excess oil.
- 5.3.3 Tap paper element **(c)** lightly to remove excess dirt. Replace paper element if it appears heavily soiled.

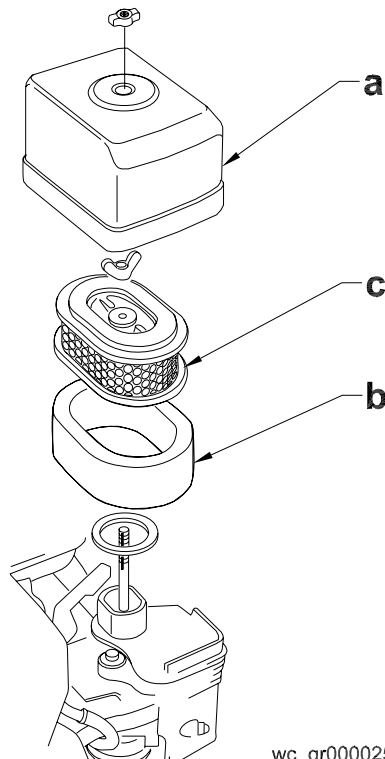

wc_gr000025

5.4 Engine Oil

See Graphic: *wc_gr000022*

- 5.4.1 Drain the oil while the engine is still warm.
- 5.4.2 Remove the oil filler plug (a) and the drain plug (b) to drain the oil.

Note: *In the interests of environmental protection, place a plastic sheet and a container under the machine to collect any liquid that drains off. Dispose of this liquid in accordance with environmental protection legislation.*

- 5.4.3 Install the drain plug.
- 5.4.4 Fill the engine crankcase with the recommended oil up to the level of the plug opening (c). See *Technical Data* for oil quantity and type.
- 5.4.5 Install the oil filler plug.

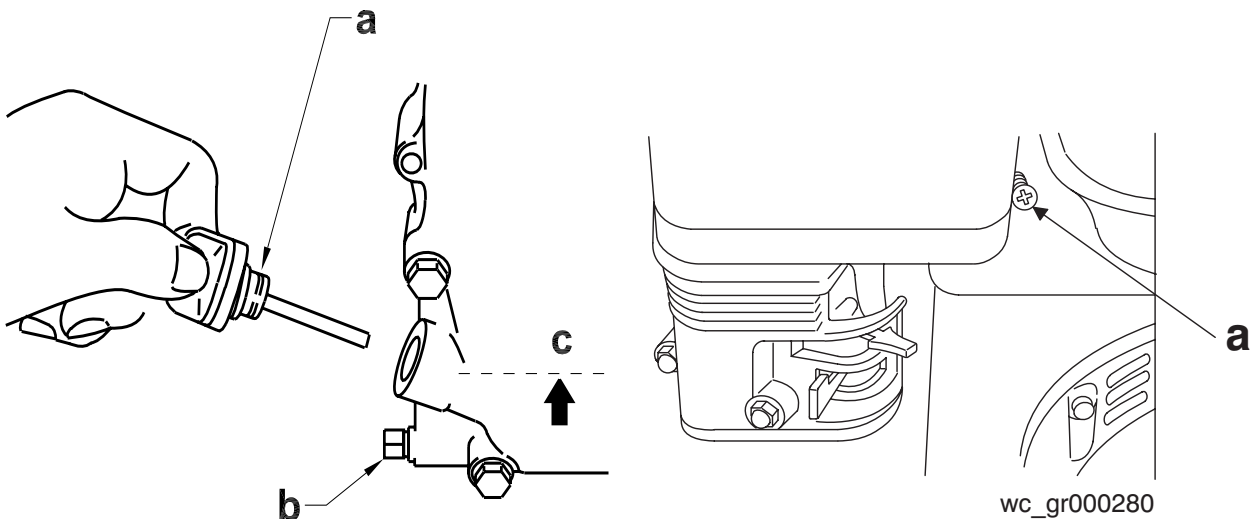

5.5 Adjusting Engine Speed

See Graphic: *wc_gr000280*

Adjust to a full load speed of 3600 ± 100 rpm.

To adjust engine speed:

- 5.5.1 Place machine on a rubber test mat to prevent it from moving.
- 5.5.2 Start engine and allow it to warm up for a minute.
- 5.5.3 Turn throttle stop screw (a) in to increase speed, out to decrease speed. Make sure throttle lever is touching stop screw before measuring RPM.

NOTICE: Running plate at a speed higher than that listed in *Technical Data* can damage both the plate and the engine.

5.6 Carburetor Adjustment

See Graphic: *wc_gr000032*

- 5.6.1 Start the engine and allow it to warm up to operating temperature.
- 5.6.2 Set the pilot screw **(a)** two turns out. See *Note*.
- 5.6.3 With the engine idling, turn the pilot screw **(a)** in or out to the setting that produces the highest rpm.
- 5.6.4 After the pilot screw is adjusted, turn the throttle stop screw **(b)** to obtain the standard idle speed. See *Technical Data*.

Note: On some engines the pilot screw is fitted with a limiter cap **(c)** to prevent excessive enrichment of the air-fuel mixture in order to comply with emission regulations. The mixture is set at the factory and no adjustment should be necessary. Do not attempt to remove the limiter cap. The limiter cap cannot be removed without breaking the pilot screw.

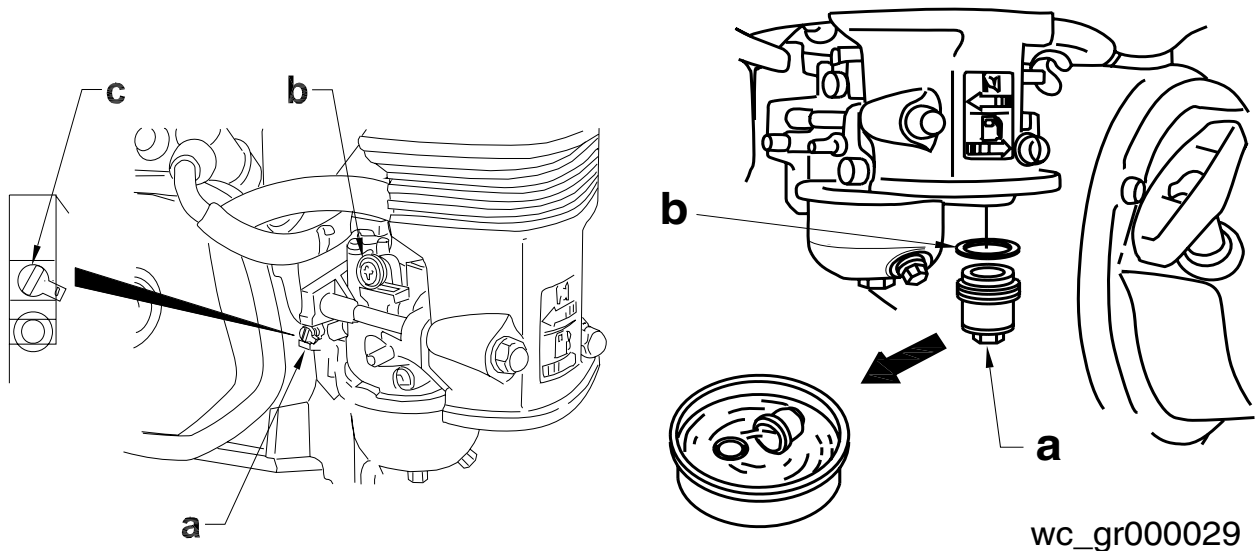

5.7 Cleaning Sediment Cup

See Graphic: *wc_gr000029*

- 5.7.1 Turn the fuel valve off.
- 5.7.2 Remove the sediment cup **(a)** and the O-ring **(b)**.
- 5.7.3 Wash both thoroughly in a nonflammable solvent. Dry and reinstall them.
- 5.7.4 Turn the fuel valve on and check for leaks.

5.8 Drive Belt

See Graphic: *wpm_gr002148*

On new machines or after installing a new belt, check the belt tension after first 20 hours of operation. Check and adjust the belt every 50 hours thereafter.

To adjust the belt:

- 5.8.1 Loosen the two screws **(a)** on the beltguard, then remove the beltguard, keeping the screw assemblies captured on the beltguard.
- 5.8.2 Loosen the four nuts **(b)** which hold the engine to the console, and the screw **(c)** which holds the beltguard back to the console.
- 5.8.3 Slide the engine backward (towards the handle) to tighten the belt, forward to loosen the belt.
- 5.8.4 Adjust the belt so that it deflects 10-13 mm (3/8in–1/2in) **(d)** when pressed midway between the belt pulleys.
- 5.8.5 Make sure that the clutch pulley **(f)** and the exciter pulley **(e)** are in alignment. Place a straight edge against the exciter pulley **(e)** and move the engine so that the two pulleys are parallel.
- 5.8.6 Torque all nuts and screws to 20.5 Nm (15 ft.lbs.) as you reassemble the machine.

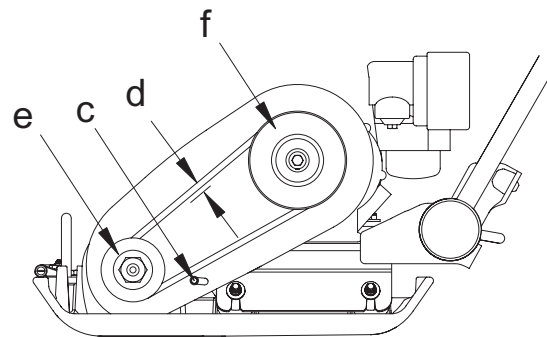
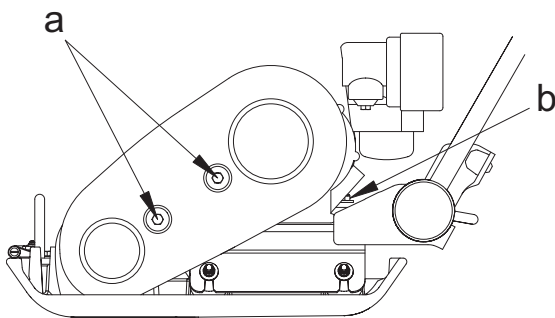

wpm_gr002148

5.9 Exciter Lubrication

See Graphic: wc_gr000291

The bearings in the exciter assembly are splash lubricated and rotate at very high speed. It is important to maintain the exciter oil at the correct level and change it regularly.

Check oil level in exciter every 50 hours of operation.

To check oil level, place plate on a flat, level surface. Remove the drain plug (a) with seal ring (b). Oil level should be at drain plug threads. Add oil as required.

Change exciter oil every 300 hours of operation.

To drain oil: Remove plug (a) from end of exciter and tilt plate up.

Note: *In the interests of environmental protection, place a plastic sheet and a container under the machine to collect any liquid which drains off. Dispose of this liquid in accordance with environmental protection legislation.*

Place plate on a level surface and add approximately 210 ml of oil through plug opening until oil reaches the drain plug threads.

NOTICE: DO NOT overfill. Too much oil in exciter can reduce performance and damage drive belt.

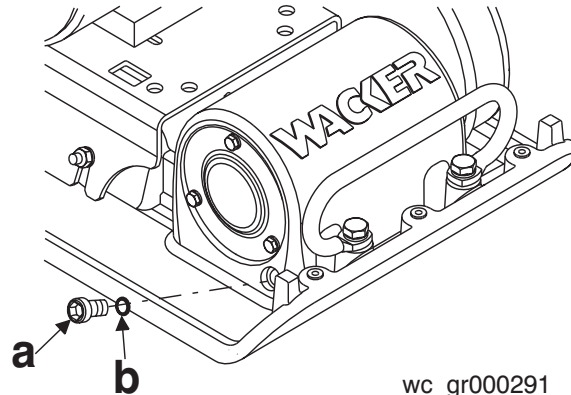

5.10 Cleaning the Plate

Clean plate after use to remove dirt, stones, and mud caught under the engine console. If plate is being used in a dusty area, check engine cylinder cooling fins for heavy dirt accumulation. Keep engine cylinder fins clean to prevent engine from overheating.

5.11 Lifting Machine

See Graphic: *wpm_gr002149*

See *Technical Data* for weight of machine.

To lift machine manually:

- 5.11.1 Stop the engine.
- 5.11.2 Obtain help from a partner and plan the lift.



WARNING

To avoid burns or fire hazards, let the engine cool before transporting the machine or storing it indoors. Turn the fuel valve to the off position and keep the engine level to prevent fuel from spilling.

- 5.11.3 Grasp machine by the lifting handles **(a)**.
- 5.11.4 Lift machine as shown.



WARNING

To reduce risk of back injury while lifting, keep feet flat on ground and shoulder width apart. Keep head up and back straight.

To lift machine mechanically:

NOTICE: Before attempting to lift, be sure that lifting devices can safely handle weight of machine. See *Technical Data* for weight of machine.

- 5.11.5 Attach hook, harness, or cable to machine as shown, and lift as desired.

NOTICE: DO NOT lift the vibroplate by its guide handle. The vibroplate can shift, causing it to fall.

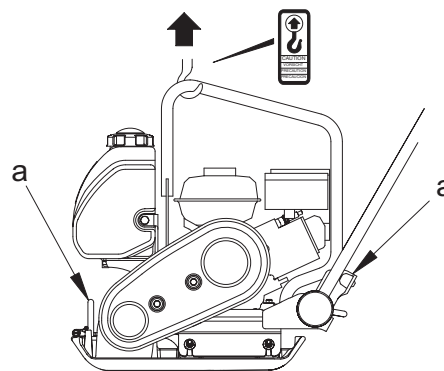
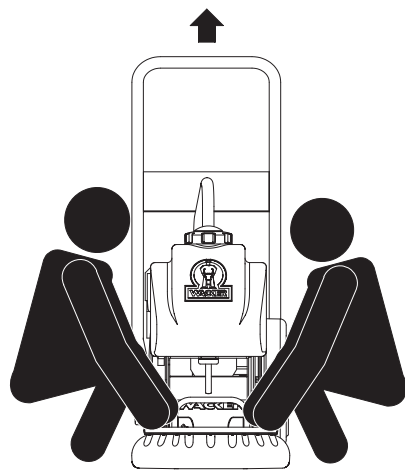

wpm_gr002149

5.12 Transporting Machine

See Graphic: *wpm_gr002150*



WARNING

To avoid burns or fire hazards, let engine cool before transporting machine or storing indoors.

- 5.12.1 Turn fuel valve to the off position and keep the engine level to prevent fuel from spilling.
- 5.12.2 Tie down machine on vehicle to prevent machine from sliding or tipping over. Tie machine to vehicle at points shown on graphic.

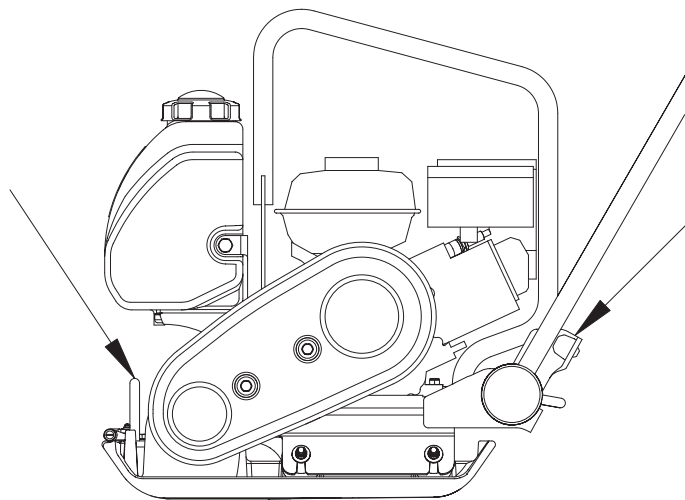

wpm_gr002150

5.13 Storage

If plate is being stored for more than 30 days:

- 5.13.1 Remove loose stones and dirt from plate.
- 5.13.2 Clean engine cylinder cooling fins.
- 5.13.3 Clean or replace air filter.
- 5.13.4 Change exciter oil.
- 5.13.5 Change engine oil and follow procedures described in engine manual for engine storage.
- 5.13.6 Cover plate and engine and store in a clean, dry area.

5.14 Troubleshooting

Problem / Symptom	Reason / Remedy
<p>Plate does not develop full speed. Poor compaction.</p>	<ul style="list-style-type: none"> • Engine throttle control not completely open. • Throttle control not adjusted correctly. • Ground too wet, plate sticking. Allow soil to dry before compacting. • Drive belt loose or worn, slipping on pulleys. Adjust or replace belt. Check that engine mounting bolts are tight. • Exciter bearings binding. Check condition and level of oil in exciter. Add or change oil. • Air filter clogged with dust, reducing engine performance. Clean or replace air filter. • Engine speed too low. Check engine speed with tachometer. Adjust or repair engine to run at correct speed. Refer to engine manual.
<p>Engine running, no vibration</p>	<ul style="list-style-type: none"> • Engine throttle not open. • Drive belt loose or broken. Adjust or replace. • Clutch damaged. Inspect and replace clutch. • Engine speed too low. Check engine speed. • Too much oil in exciter. Adjust oil to correct level.
<p>Plate jumps or compacts unevenly.</p>	<ul style="list-style-type: none"> • Ground surface too hard. • Shockmounts loose or damaged.

**EC DECLARATION OF CONFORMITY
EG-KONFORMITÄTSERKLÄRUNG
CE-DECLARACIÓN DE CONFORMIDAD
DÉCLARATION DE CONFORMITÉ DE LA CEE**

WACKER MACHINERY PHILIPPINES, INC., DASMARIÑAS, CAVITE, PHILIPPINES

AUTHORIZED REPRESENTATIVE IN THE EUROPEAN UNION
BEVOLLMÄCHTIGTER VERTRETER FÜR DIE EUROPÄISCHE GEMEINSCHAFT
REPRESENTANTE AUTORIZADO EN LA UNIÓN EUROPEA
REPRÉSENTANT AGRÉÉ AUPRÈS DE L'UNION EUROPÉENNE

WACKER CONSTRUCTION EQUIPMENT AG
Preußenstraße 41
80809 München

hereby certifies that the construction equipment specified hereunder / bescheinigt, daß das Baugerät / certifica que la máquina de construcción / atteste que le matériel :

1. Category / Art / Categoría / Catégorie

**Vibratory Plates / Rüttelplatten
Planchas Vibratorias / Plaques Vibrantes**

2. Type - Typ - Tipo - Type

VP 1135A, VP 1135AW

3. Item number of equipment / Artikelnummer / Número de referencia de la máquina / Numéro de référence du matériel :

0009057, 0009058

4. Net installed power / absolute installierte Leistung / Potencia instalada neta / Puissance installée nette :

3,0kW

Has been sound tested per Directive 2000/14/EC / In Übereinstimmung mit Richtlinie 2000/14/EG bewertet worden ist / Ha sido ensayado en conformidad con la norma 2000/14/CE / A été mis à l'épreuve conforme aux dispositions de la directive 2000/14/CEE :

Conformity Assessment Procedure / Konformitätsbewertungsverfahren / Procedimiento para ensayar conformidad / Procédé pour l'épreuve de conformité	Name and address of notified body / Bei folgender einbezogener Prüfstelle / Oficina matriculadora / Organisme agréé	Measured sound power level / Gemessener Schallleistungspegel / Nivel de potencia acústica determinado / Niveau de puissance acoustique fixé	Guaranteed sound power level / Garantierter Schallleistungspegel / Nivel de potencia acústica garantizado / Niveau de puissance acoustique garanti
Annex VI / Anhang VI / Anexo VI / Annexe VI	VDE-Prüf- und Zertifizierungsinstitut Zertifizierungsstelle Merianstraße 28 63069 Offenbach/Main	VP 1135A 100 dB(A) VP 1135AW 100 dB(A)	VP 1135A 105 dB(A) VP 1135AW 105 dB(A)

and has been produced in accordance with the following standards / und in Übereinstimmung mit folgenden Richtlinien hergestellt worden ist / y ha sido fabricado en conformidad con las siguientes normas / et a été produit conforme aux dispositions des directives européennes ci-après :

**2000/14/EG
98/37/EG
89/336/EG
EN 500-1
EN 500-4**

09.02.06

Date / Datum / Fecha / Date

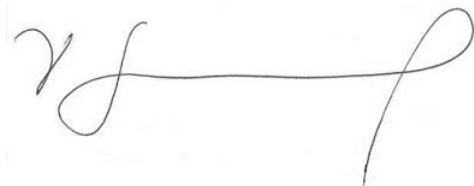

Heinz Gengnagel
President & CEO

WACKER MACHINERY PHILIPPINES

WACKER MACHINERY PHILIPPINES, INC.

4126 First Cavite, Industrial Estate (FCIE) Governor's Drive, Brgy. Langkaan
Dasmariñas, Cavite, Philippines (Tel) +63 2 580 7110 (Fax) +63 2 580 7122



